

CHAPTER 2. ADJUSTMENTS

[1] Adjustments

General

Since the following adjustments and settings are provided for this model, make adjustments and/or setup as necessary.

1. Adjustments

Adjustments of output voltage (FACTORY ONLY)

1. Install the power supply unit in the machine.
2. Set the recording paper and document.
3. When the document is loaded, power is supplied to the output lines. Confirm that outputs are within the limits below.

Output voltage settings

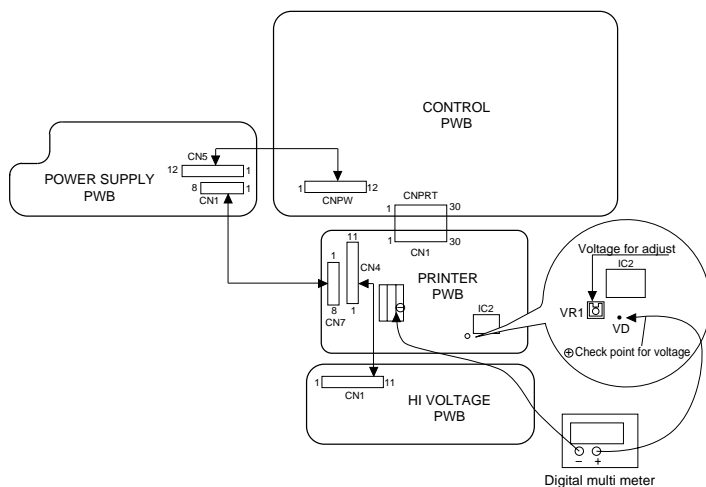

Fig. 1

Output	Voltage limits
+5V MAIN	4.845V~5.355V
+5V SUB	4.845V~5.355V
+24V MAIN	23.04V~24.96V
+24V SUB	23.04V~24.96V

Connector No. Pin No.	CN4	CN1
1	11	+5V
2	10	HV C HL
3	9	T VR
4	8	T REM
5	7	T MON
6	6	B MON
7	5	B VR
8	4	C REM
9	3	C MON
10	2	MG
11	1	+24

Connector No. Pin No.	CN5	CNPW
1	+24V SUB	
2	MG	
3	MG	
4	MG	
5	+24V MAIN	
6	+24V MAIN	
7	+5V SUB	
8	DG	
9	DG	
10	DG	
11	+5V MAIN	
12	+5V MAIN	

Connector No. Pin No.	CN1	CN7
1	24 MAIN	
2	MG	
3	DG	
4	5V MAIN	
5	HEATER ON	
6	FAN	
7	FAN LOCK	
8	H RELAY OFF	

ADJUST VOLTAGE LIST

Top Void Printer Label (mm.) Fig. 2	Adjust Voltage VR1 Fig. 1
5.5~6.9	4.42V
7.0~8.9	3.87V
9.0~10.9	3.14V
11.0~12.9	2.50V
13.0~14.9	1.86V
15.0~17.0	1.22V

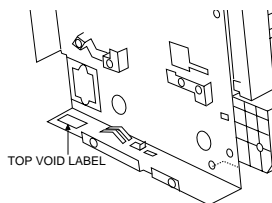

Fig. 2

2. IC protectors replacement

ICPs (IC Protectors) are installed to protect the TX motor drive circuit and verification stamp drive circuit. ICPs protect various ICs and electronic circuits from an overcurrent condition.

The location of ICPs are shown below:

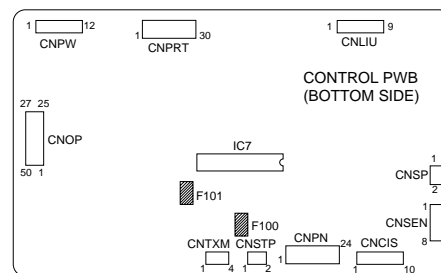

Fig. 3

- (1) F100 (ICPS10) is installed in order to protect IC's from an overcurrent generated in the verification stamp drive circuit. If F100 is open, replace it with a new one.
- (2) F101 (ICPS18) is installed in order to protect IC's from an overcurrent generated in the TX motor drive circuit. If F101 is open, replace it with a new one.

In addition to the replacement of F101 and F100, the factor causing F101 and F100 to open must also be repaired. If not, F101 and F100 will open again.

Replacement parts

ICPS10 (Sharp code: VHViCPS10// -1)

ICPS18 (Sharp code: VHViCPS18// -1)

3. Settings

(1) Dial mode selector

OPTION SETTING: DIAL MODE (Soft Switch No. SW2 DATA No. 1)
Use this to set the fax machine to the type of telephone line you are on.

- The factory setting is "TONE".

(step 1) Select "OPTION SETTING".

KEY: **FUNCTION** (4)

DISPLAY: 4:OPTIONAL SETTING
ENTER #(01-34,*,#)

(step 2) Select "DIAL MODE".

KEY: (2)(2)

DISPLAY: DIAL MODE ↔ 1=TONE, 2=PULSE

Cursor
When initially registering, the mode shows 1=TONE. When registering again, the mode which was registered formerly is shown.

(step 3) Select, using "1" or "2".

KEY: (1)

DISPLAY: TONE SELECTED

KEY: (2)

DISPLAY: PULSE SELECTED

(step 4) End, using the "STOP" key.

KEY: **STOP**

[2] Diagnostics and service soft switches

1. Operating procedure

Two kinds of diagnoses are supported.

1-1. Fax diagnosis

This diagnosis is concerned with the main body of fax which is used for production and service support.

Entering the diagnostic mode

Press **FUNC** → **9** → ***** → **8** → **#** → **7**, and the following display will appear.

```
U: ROM: FBN0*
C: ROM: FBPO*
```

```
FBNO*
FBPO*
```

Then press the **START** key. Select the desired item with the ***** key and the **#** key or select with the rapid key.

Enter the mode with the **START** key.

(Diag •specifications)

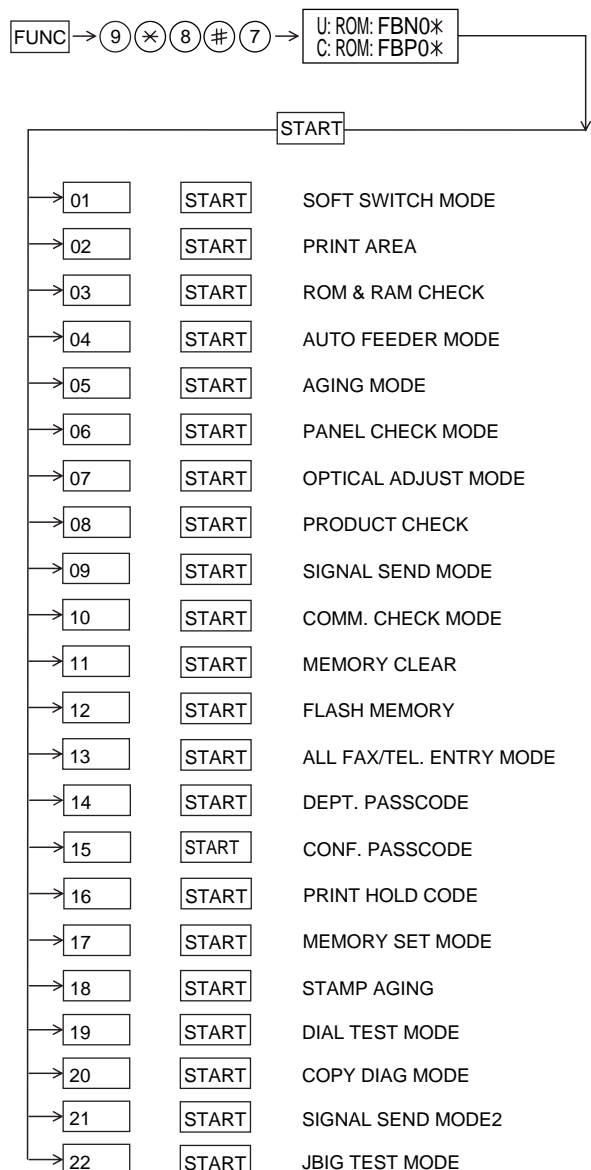

1-2. Print diagnosis

This diagnosis is concerned with the print which is used for production and service support.

Entering the diagnostic mode

Press **FUNC** → **9** → ***** → **8** → **#** → **6**, and the following display will appear.

```
PCU ROM Ver.: **
```

Then press the **START** key. Select the desired item with the ***** key and the **#** key or select with the rapid key.

Enter the mode with the **START** key.

(Diag •specifications)

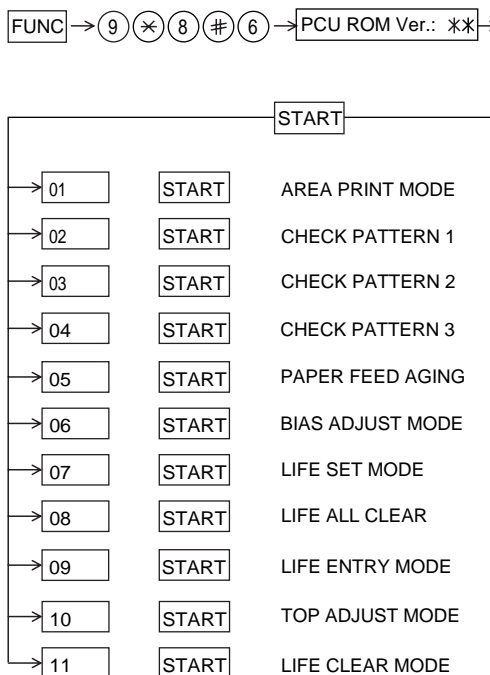

Memory clear when power is turned on

Pressing the **START** and **STOP** keys, turn on the main power, and the following message will be displayed.

```
MEMORY CLEAR
EXECUTE ? 1 = YES , 2 = NO
```

Here, when 1: YES is selected, the memory will be cleared to be ready for operation.

If 2: NO is selected, it will continue ready for operation as it is.

2. Diagnostic items description

2-1. Fax diagnosis

1) Soft switch mode

In this mode, the soft switch are set and the soft switch list is printed.

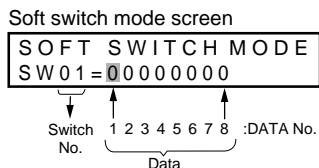

- ① Switch number selection
 - Press START key for setting of the next soft switch. If the soft switch number is the final, pressing START key will exit the soft switch mode.
 - Enter two digits of a soft switch number to set the switch number. If a switch number of unexisting soft switch is entered, key error buzzer sounds to reject the input.



- ② Data number selection

The cursor position shows the data to be set.
Pressing # key moves the cursor to the right. If, however, the cursor is on data number 8, pressing # key shifts the cursor to data number 1 of the next switch number. If the switch number is the final, pressing # key will exit the soft switch mode.
Pressing \times key moves the cursor to the left. If, however, the cursor is on data number 1, pressing \times key shifts the cursor to data number 1 of the former switch number. If the switch number is 1, pressing \times key will not move the cursor and the error buzzer will sound.
- ③ Data setting method

Press the FUNCTION key, and the data at the position of the cursor will be reversed to 0 when it is 1, or to 1 when it is 0. (If the soft switch can be changed at the bit (Refer to ⑥.), the error buzzer will sound with the process not received.)
- ④ Outputting method of soft switch list

In the soft switch mode, press the REPORT key, and the soft switch list will be output.
If the recording paper runs out or is clogged, the key error buzzer will sound with the process not received.
- ⑤ Storage of data

In the following case, the data of the soft switches set will be stored.

 - It is shifted to set the next soft switch by pressing the START switch.
 - It is shifted to set the next soft switch with the [#] key.
 - It is shifted to set the last soft switch with the [\times] key.
 - It is shifted to set another soft switch by inputting two digits as the switch number. (When 2 digits are completely input.)
 - Output of the soft switch list is started.
- ⑥ Inhibition of data change

(This is also applicable for the optional setting.)
In the following case, it is inhibited to change the data with the key error buzzer.

 - Switching ON/OFF of ECM during the use of image memory.
 - Switching OFF to ON of the print hold function when the print hold pass code has not yet been registered.
 - Clearing the print hold pass code when print hold function is ON.
 - Switching ON/OFF of the print hold function during the use of memory such as in the case of substitute receiving.

- OFF to ON of telephone billing function which is using the image memory is used (Note: In the existing set, the telephone billing code function is specified from OFF to ON when the timer system communication (including the batch communication) is set.) Here, the memory is usable when the telephone billing code function is on. It can be set from ON to OFF while the memory is used. However, if setting is practically changed even once, it can not be returned from OFF to ON.
 - Switching ON/OFF of PC interface function during the use of image memory.
 - OFF to ON of department control function during use of image memory. (Note: In the existing set, the department control function is set from OFF to ON when the timer communication (including the batch sending) or the memory hold is set.)
 - ON to OFF of continuous serial polling function when the continuous serial polling is started. (Note: In the existing set, "ON to OFF of the continuous serial polling function when the continuous serial polling is registered" has been applied, but the conditions are now moderated. However, registration is impossible to the program of the new continuous serial polling when the continuous serial polling function is OFF.)
 - In addition, change of all soft switches during communication
- ⑦ Linked change of data (This is the same even in the optional setting.)
 - When the department control function is off, the multi TTI function and telephone billing code function are turned off.

2) Print area

According to the size of the specified sheet, the effective printing area is printed.

3) ROM & RAM check

The sum value of ROM, the work and the back-up RAM are checked. The RS232C interface is also checked. If any error occurs, the buzzer will inform it. (Refer to the following table). Finally, the result will be printed. This diagnosis does not check the flash memory. The flash memory is checked with the flash memory test.

Number of buzzer sounds	Device checked	Remarks
1 time <Short sound>	ROM	Main
2 times <Short sounds>	Integrated ROM	Main
3 times <Short sounds>	SRAM	Main
4 times <Short sounds>	DRAM	Main

For the short and long sounds, one pattern is as follows.

Main system: 0.5 seconds ON/0.5 seconds OFF

Sub system: 1.00 second ON/0.5 seconds OFF

The execution state of checking is as follows. Moreover, the list of the check result is output after checking is ended.

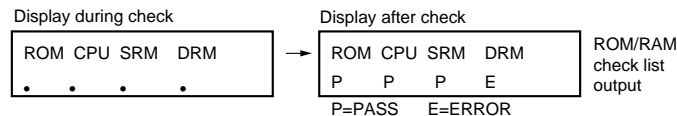

4) Auto feeder mode

The auto feed function can be checked by inserting and discharging the document. (The distance between pages can be displayed during operation of the scanner.)

① Check of auto feed function

After this mode is activated, set up the document, and press the START key, and it will be automatically fed. (Before the START key is pressed, the document sensor alone is activated.) Moreover, the document size (A4/B4) and sensor information (A4/B4/ORG) are displayed when the document sensor is turned.

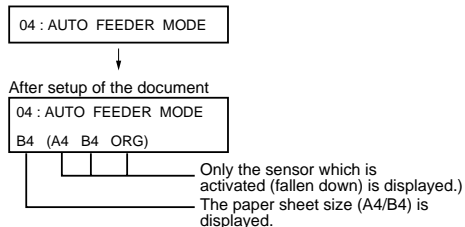

② Display of distance between pages during operation of the scanner

- Soon after this mode is activated, press the FUNCTION key for 5 seconds or more, and the display mode of the distance between pages will be activated. Then, set up the sending paper and select the image quality, and then press the START key, and operation will be started.

Be sure to press the FUNCTION key prior to the START key. If the FUNCTION key is not pressed but the START key is pressed, it will operate in the same matter as in the existing auto feeder mode.

If the START key is pressed, the FUNCTION key will be invalid hereafter. Therefore, the display mode of the distance between pages and the existing mode can not be changed.

- While the sending paper is read, the image quality key can be input. STD/FINE/S-FINE modes are usable. However, the same operation of FINE will be selected if the intermediate tone is set.
- The image quality, the length of the sending page read, the page distance to the next sending paper and the total of the sending papers read are shown on the display.
- When the stop key is pressed or 100 sending papers are read, the content shown on the display will be totally output as the list after the remaining sending papers are discharged.

5) Aging mode

If any document is set up in the first state (when started), copying will be executed. If it is not set up, "check pattern 1" of the print diagnosis is output at the intervals of 1 time/60 minutes. (A total of 10 sheets are output.)

6) Panel check mode

This is used to check whether each key is normally operated or not. According to the key input, LCD is displayed. Moreover, during execution, the document reading lamp is turned on.

Test results are printed. (The maximum 100 input keys can be printed.) LED repeats lighting at regular intervals in sequence. (Lighting speed is specified separately.)

In case of inputting all keys, key input OK is displayed when finishing the STOP key.

When pressing the NUMERIC key during panel check, output of DTMF corresponding with the key is started.

When pressing other keys, output is stopped.

7) Optical adjust mode

Set documents and press the START key for ordinary copying. According to key operation, copying can be temporarily stopped. STOP key: To temporarily stop reading documents. START key: To start reading documents again. When any document is not set, print area printing is performed.

8) Product check

The diagnosis is used in the production process. After shift to the mode, the following operations are sequentially executed. At this time, the sensor of read-error can be checked by feeding the B4 document. Set up one short document of B4 size.

- ① Memory clear (Same as Diagnosis 11)
 - ② Panel test (Same as Diagnosis 06)
 - ③ Dial test (Same as Diagnosis 24)
 - ④ Document auto feed
 - ⑤ ROM & RAM test check (Same as the Diagnosis 03)
 - ⑥ Flash memory test mode (Same as Diagnosis 12)
 - ⑦ Registration of fixed data
 - Registration of rapid key No. and other data necessary for production.
 - The registered data are shown in the following table. The chain dial is not set for any destination.
- | Rapid No. | FAX No. | Rapid No. | FAX No. | Rapid No. | FAX No. | Rapid No. | FAX No. |
|-----------|---------|-----------|---------|-----------|---------|-----------|---------|
| 01 | 20 | 06 | 25 | 11 | 1 | 21 | 01 |
| 02 | 21 | 07 | 26 | 12 | 2 | 22 | 02 |
| 03 | 22 | 08 | 27 | 13 | 3 | 23 | 03 |
| 04 | 23 | 09 | 28 | 14 | 4 | 24 | 04 |
| 05 | 24 | 10 | 29 | 15 | 5 | 25 | 05 |
- ⑧ Transmission check (Same as Diagnosis 10)
 - The soft switches necessary for production are set.
 - ⑨ Test result print (one sheet)
 - Memory clear printing
 - Panel test result printing
 - ROM & RAM test result printing
 - ⑩ Print area printing (one sheet)

9) Signal send mode

After shift to the mode, press the START key, and the signals will be transmitted in the following sequence.

It can be used to check the modem and so on.

- [1] No signals
- [2] 4800BPS (V27ter)
- [3] 14400BPS (V. 33)
- [4] 12000BPS (V. 33)
- [5] 14400BPS (V. 17)
- [6] 12000BPS (V. 17)
- [7] 9600BPS (V. 17)
- [8] 7200BPS (V. 17)
- [9] 9600BPS (V. 29)
- [10] 7200BPS (V. 29)
- [11] 4800BPS (V27ter)
- [12] 2400BPS (V27ter)
- [13] 300BPS (FLAG)
- [14] 2100Hz (CED)
- [15] 1100Hz (CNG)

10) Comm. check mode

- ① Turn on the line monitor.
- ② Turn off the COVER SHEET FUNCTION.
- ③ Set line equivalence at 0 km.

After the check, it is necessary to be sure to return the aforementioned soft switches into the initial state.

(Clear the memory with the diagnosis.)

11) Memory clear

Clear the back-up memory to initialize the soft switches.

The flash memory will be initialized. Then, the initialized list be output.

12) Flash memory

The flash memory is checked.

The ordinary memories (ROM, SRAM, DRAM) are checked in the ROM & RAM check process. The write/read test is taken every block to print the result.

When an error occurs, the following error buzzer will sound.

Number of buzzer sounds	Check device
9 times <Short sounds>	Flash memory (Option)

During operation of this diagnosis, dual operation is not possible at all. If this is excessively repeated, it will shorten the life of the flash memory.

13) All FAX/TEL. entry mode

The function is used to simplify the registration of FAX/TEL No. during aging.

- ① The diagnosis mode is activated. If anything is not registered in the Rapid number 01 or any program or group is not registered, it will pass the diagnosis without doing anything.
- ② The FAX/TEL number (including the substitutive destination) of the Rapid number 01 is copied to the Rapid numbers 02 thru 48.
- ③ FAX number of the Rapid number 01 is copied to SPEED key numbers 001 thru 200.

- ④ If any chain dial is not in the Rapid number, the Rapid numbers 02 thru 48 and SPEED key numbers 001 thru 200 are registered in the group number 01.

If any chain dial is set, the group will be not produced but the chain dial setting alone of the Rapid number 01 will be reset.

(In all others except the Rapid number 01, the chain dials will be continuously set as they are.)

Rapid key RXX XX : Rapid number
SPEED key SXXX XXX : Speed key number

(16th and subsequential letters of the destination name registered in the Rapid number 01 will be discarded.)

14) Dept. passcode

The department passcode list is printed.

15) Conf. passcode

The confidential passcode list is printed.

Differing from printing of one box alone soon after registration, the confidential passcodes of all boxes are printed.

16) Print hold code

The print lockout passcode No. is printed.

17) Memory set mode

The set and dump list of the memory content is output.

- The address (8 digits (P) generally including the bank information is input, and the data of 2 digits is continuously input. Inputting is done in the hexadecimal mode. The ten-key is used for 0 thru 9, and the alphabetic keys A (RAPID 01 thru 06) are used for A thru F.
- During data inputting, the address can be moved forward and backward one byte by one byte with "×" and "#". (The address prior to the address 0 is looped as the maximum address.)
- The Validity of the address is not checked. Accordingly, writing/ reading operations are possible in the address of the memory not assigned, the address of ROM and so on. (However, as practical, writing is not done, and the data content runs short each reading.)
Though writing is possible in the flash memory, a little time is required.
It is also necessary to take care that the life of the flash memory is excessively shortened if much data is written in the flash memory. Since it may run away depending the written content, take minute care for the writing address.
- When the REPORT key is input, the memory dump list is produced from the displayed address (here, it is limited at the 16-byte boundary address (address with end 0) which does not exceed the specified address and is just in front.). The dump list is output to a maximum of 99 pages. If any data of one page can be repeatedly developed and printed, the list is sufficient. But it is not desired that the content of plural pages are developed in the memory once and are then printed. If the STOP key is pressed, it will pass to the diagnosis after the page which is now being printed is completed printed.
If the address exceeds the maximum address, it will return to the address 0 and printing will be continued.

18) Stamp aging

Diag mode is left though it doesn't have this function.

19) Dial test mode

The mode is used to inspect whether dialing is accurate in two kinds of dial modes. All data which can be dialed in this mode are automatically called up in both PB mode and DP mode.

When this mode is activated, the following operations will be automatically executed. Whether the dialed content is right or not is judged with the external instrument which is connected to the line cable.

- ① After shift to the FAX diagnosis mode, press RAPID 24.
(Also switch the display with the [×] and [#] keys.)
- ② Press the START key.
- ③ Turn on CML, and dial the following in the PB mode.
1, 2, 3, 4, 5, 6, 7, 8, 9, ×, 0, #
- ④ Turn off CML 500 mS alone.
- ⑤ Dial the following in the DP mode.
1, 5, 9, 0
- ⑥ After dialing, turn off CML.

This mode uses the ordinary auto dial. (Accordingly, the signal sending time and minimum pause are all the same as ordinary.)

The measurement result in this mode is completely all the same as in the ordinary dial mode.

Moreover, the same process as above is also done in the dial test mode which is executed in the product check mode.

20) Copy diag mode

In order to shorten the process time during production, this mode is used to automatically switch the copy mode. Three menus are provided.

1. ① Set up two documents. (In case of two documents or more, there is no problem.)
- ② Press the START key.
- ③ Copy 1st document in the fine mode/density AUTO. (One sheet is printed in the ordinary copy mode.)
- ④ Copy 2nd (subsequential) document in the intermediate tone mode/density DARK. (In the ordinary copying mode, one sheet is printed when the RESOLUTION key is pressed three times.)

When copy test is tried during production or is checked in two modes (fine and intermediate tones), this mode is provided to reduce the troublesome work which makes the operator stand aside to change the mode. Accordingly, the fine and intermediate tones are merely switched, and the mode is not switched to another mode. (Input of the image quality/density key is invalid.)

2. Try the copy in the mode fixed at COPY REDUCE 95% and fine mode/density AUTO. At this time, don't change the soft key of COPY REDUCE. (Input of the image quality/density key is invalid.)
3. Continuously try the above items 1 and 2.

21) Signal Send Mode2

The signals concerned with V.34 & V.8 are checked.

After this mode is activated, press the START key, and the signals will be sent in the following sequence.

It can be used to check the modem.

- [1] No signal
- [2] 33600BPS
- [3] 31200BPS
- [4] 28800BPS
- [5] 26400BPS
- [6] 24000BPS
- [7] 21600BPS
- [8] 19200BPS
- [9] 16800BPS
- [10] 14400BPS
- [11] 12000BPS
- [12] 9600BPS
- [13] 7200BPS
- [14] 4800BPS
- [15] 2400BPS

22) JBIG Test Mode

- ① Enter the diagnostic mode.
- ② Press the RAPID22 button. ("22: JBIG TEST MODE" appears.)
- ③ Press the START key to begin the JBIG test operation.

When both tests are completed normally, the buzzer sounds and "JBIG TEST NORMAL END" appears at the same time.

If the decoding test terminates abnormally, the buzzer sounds and "ERROR: JBIG DECODE" appears at the same time.

If the encoding test terminates abnormally, the buzzer sounds and "ERROR: JBIG ENCODE" appears at the same time.

2-2. Print diagnosis

Rapid key 01: Area print mode

The effective printing area frame is printed in the specified sheet size.

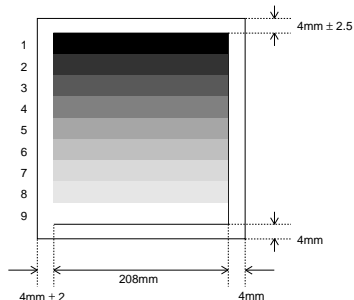

1. [Full black pattern]
2. [Intermediate tone 2 pattern]

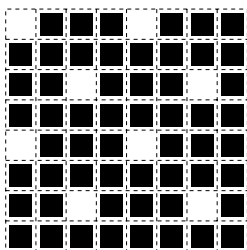

The left pattern is repeated.

3. [Intermediate tone 1 pattern]

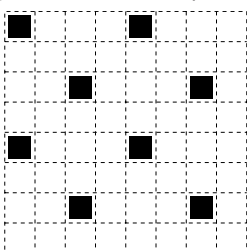

The left pattern is repeated.

4. [Mesh point pattern]

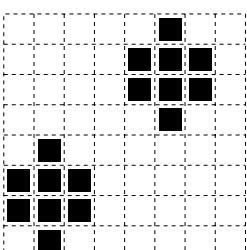

The left pattern is repeated.

5. [Longitudinal strip 2 pattern]
Black 2 dot and white 2 dot are repeated in line.
6. [Lateral strip 2 pattern]
Black 2 line and white 2 line are repeated.
7. [Longitudinal strip 1 pattern]
Black 1 dot and white 1 dot are repeated in line.
8. [Lateral strip 1 pattern]
Black 1 line and white 1 line are repeated.
9. [Full White pattern]

Rapid key 02: Check pattern 1

The lateral stripe 2 pattern is printed on one sheet.
(Black 2 line and white 2 line are repeated.)

Rapid key 03: Check pattern 2

The lateral stripe 2 pattern is printed on multiple pages.
Press the STOP key to end the printing.

Rapid key 04: Check pattern 3

The intermediate tone 1 is printed on one sheet.

Rapid key 05: Paper feed aging

The mode is used for aging related to the printing. In this mode, the following modes are provided.

- ① Blank paper aging mode (ALL WHITE AGING)
- ② Whole black print aging mode (ALL BLACK AGING)
- ③ 4% printing aging mode (4% AGING)

After selecting the paper-pass aging mode in the print diagnosis mode, input the number of each mode above with the ten-key, and the mode will be executed. The detailed specifications of each mode are described as follows. Here, the operation in each mode is stopped only when the STOP key is pressed by the operator or a printing-impossible error occurs.

- Blank paper aging mode
In the mode, printing is continued in the whole white (white paper) printing pattern until the STOP key is pressed by the operator. (In the printing area)
- Whole black printing aging mode
In the mode, printing is continued in the whole black (whole black) printing pattern until the STOP key is pressed by the operator. (In the printing area)

Rapid key 06: Bias adjust mode

The mode is used to adjust the printing density of the printed image. The image printing density is adjustable in seven steps of 1 to 7.

For details, refer to the following table. (For selection, use the keys 1 thru 7.)

Image printing density	Thin	←	→	Thick			
	1	2	3	4	5	6	7
Default value				⊙			

Rapid key 07: Life set mode

The mode is used to set the life counter of the printer and the counter of the auto feeder at desired values. For setting, proceed with the following procedure.

- ① When the life counter setting mode is selected, the following will be displayed.

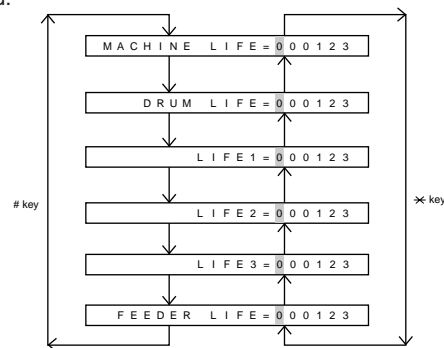

The cursor blinks at the top data.

Five counters can be selected with the "#" and "x" keys.

- ② In the state ①, input a desired setting number of 6 digits with the ten-key.
- ③ After input of 6 digits, shift to another counter with the "#" and "x" keys as necessary. When all necessary counters are completely input, press the START key.
- ④ "STORED" will be displayed with the set values stored into the memory.
For checking, retry this mode.

Note:

This counter indicates the printer use conditions such as numbers of printed pages from the beginning of use. In the normal memory clear condition, the counter will not be reset.

In conditions including damaged memory contents caused by repairing the panel, this counter should be reset or cleared in addition to the ordinary memory clear.

Rapid key 08: Life all clear

The mode is used to clear the life counter of the printer or the counter of the auto feeder.

Note: The counter shows the operational state of the printer (e.g. how many sheets have been printed since start of use?). The ordinary memory does not reset the counter. Accordingly, it is necessary to reset this counter in addition to the ordinary memory clear if the content in the memory on the control PWB is broken because of PWB repair, etc. (In the production stage, it is necessary to execute this in the last process.)

**Rapid key 09: Life entry mode
(For Serviceman temporary counter)**

The mode is used to set a desired value for the judgment value (alarm judgment counter value) of the general purpose life counters 1 thru 3 of the printer. If the life of a consumable part (developer, imprinter, etc) is set, the model which has the error display and RMS function will inform RMS when the counter reaches the set value. For setting, proceed with the following procedure.

- ① When the life counter setting mode is selected, the following will be displayed.

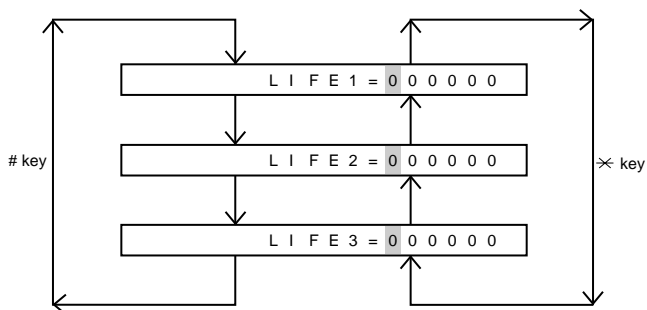

The cursor blinks at the top data.

Three counters can be selected with the '#' and 'x' keys.

- ② In the state ①, input a desired setting number of 6 digits with the ten-key.
- ③ After input of 6 digits, shift to another counter with the '#' and 'x' keys as necessary. When all necessary counters are completely input, press the START key.
- ④ "STORED" will be displayed with the set values stored into the memory. For checking, retry this mode.

Note: The counter shows the operational state of the printer (how many sheets have been printed since start of use? and others). The ordinary memory does not reset the counter. Accordingly, it is necessary to reset the counter or do the clear process in addition to the ordinary memory clear if the content in the memory on the control PWB is broken because of PWB repair, etc. (In the production stage, it is necessary to execute this in the last process.)

Rapid key 10: Top adjust mode

As the method to adjust the top margin for printing, adjust top margin adjusting VR on the PWB. If this mode is used at this time, adjustment is possible without the printing test every time when VR is turned.

For the practical use, determine the adjusting value on the basis of the old data, and adjust to the determined value in this mode. Then, check it with the printing test.

Rapid key 11: Life clear mode

The mode is used to respectively clear the life counter of the printer and the counter of the auto feeder. For setting, proceed with the following procedure.

- ① When the life counter clearing mode is selected, the following will be displayed.

Seven counters can be selected with the '#' and 'x' keys.

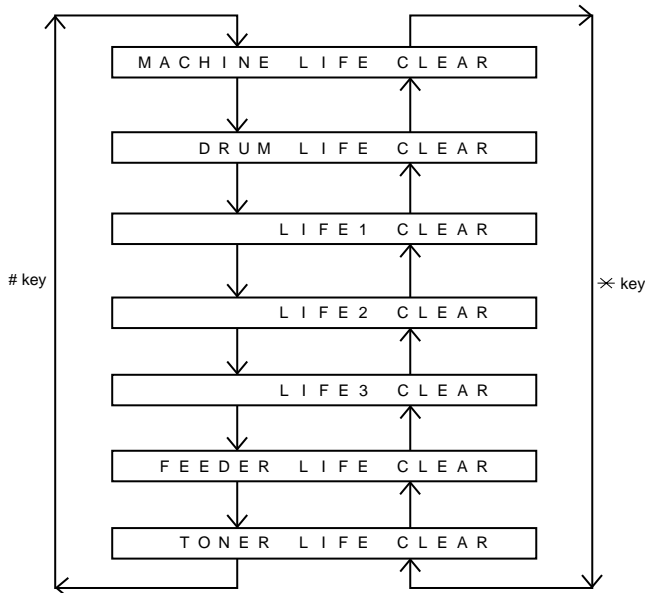

- ② In the state ①, input the CLEAR key, and the counter will be respectively cleared.
- ③ After one clear, move the cursor to another counter with the '#' and 'x' keys as necessary, and then press the CLEAR key. When the necessary counters are completely cleared, press the STOP key.

3. How to make soft switch setting

To enter the soft switch mode, make the following key entries in sequence.

Press **FUNCTION** **9** ***** **8** **#** **7** **START** **0 1** **START**

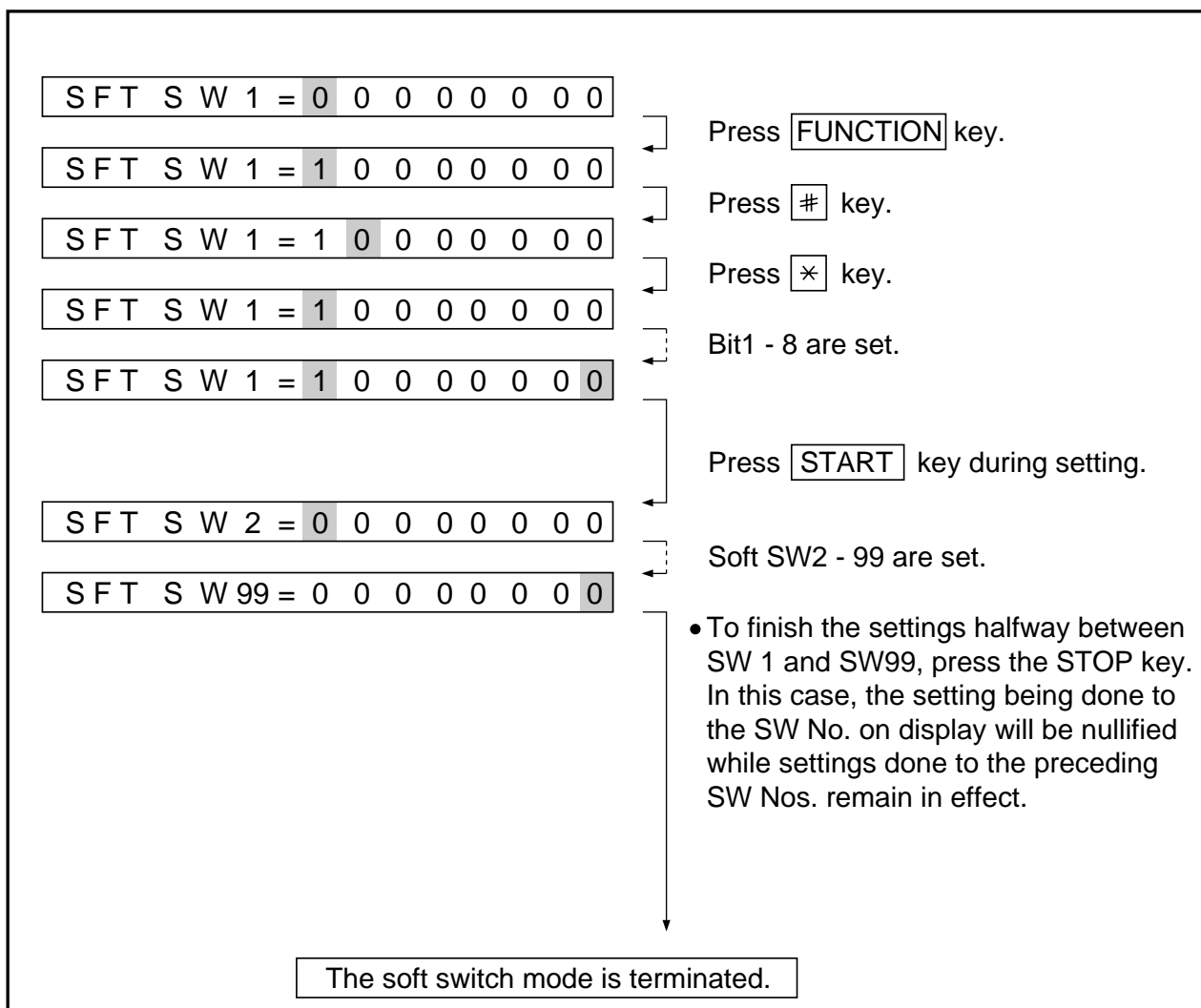

4. Soft switch description

• Soft switch

SW NO.	DATA NO.	ITEM	Switch setting and function					Initial setting	Remarks	
			1			0				
SW1	1	Recall interval	Binary input 8 4 2 1					0	OPTION Set to 1~15	
	2		No. = 1 2 3 4 (Data No.)					1		
	3		EX 0 1 0 1					0		
	4		eg. Recall interval is set to 5 min.					1		
	5	Recall times	Binary input 8 4 2 1					0	OPTION Set to 0~14	
	6		No. = 5 6 7 8 (Data No.)					0		
	7		EX 0 0 1 0					1		
	8		eg. Recall times is set to 2 times.					0		
SW2	1	Dial mode	PULSE			TONE		0		
	2	Receive mode	AUTO			MANUAL		1		
	3	ECM mode	Off			On		0	OPTION	
	4	Reserved						0		
	5	Polling security	On			Off		1	OPTION	
	6	Auto cover sheet	No			Yes		1	OPTION	
	7	JUNK-FAX function in manual reception	Yes			No		0		
	8	JUNK-FAX function	Yes			No		0	OPTION	
SW3	1	Number of rings for auto-receive (0: No ring receive)	Binary input 8 4 2 1					0	OPTION Set to 0~9	
	2		No. = 1 2 3 4 (Data No.)					0		
	3		EX 0 0 0 1					0		
	4		eg. Number of rings for auto receive is set to 1 time.					1		
	5	Switch to auto-receive from manual receive (0: No switch)	Binary input 8 4 2 1					0	OPTION Set to 0~9	
	6		No. = 5 6 7 8 (Data No.)					0		
	7		EX 0 0 0 0					0		
	8		eg. Switch to auto receive is set to disable.					0		
SW4		Communication results printout		Printed at error only	Printed at error/timer/memory only	Printed at transmission mode only	Not printed	Printed every time	OPTION	
	1		No. 1	0	0	0	1	1		0
	2		No. 2	0	0	1	0	1		0
	3		No. 3	1	0	0	0	0		1
	4	Image addition function to the communication result table (for memory transmission only)	On			Off		1	OPTION	
	5	Reserved						0		
	6	TEL billing code function	On			Off		0	OPTION	
	7	Billing code position	Before			After		1	OPTION	
	8	Multi-TTI feature	On			Off		0	OPTION	
	SW5	1	Time display format	24 hours			12 hours-AM/PM		0	
2		Date display format	Month-Day-Year			Day-Month-Year		1		
3		Header print	Off			On		0		
4		Footer print	On			Off		0		
5		Relay data output	No			Yes		0		
6		Substitute reception	Off			On		0		
7		Substitute reception conditions	Reception disable without TSI			Reception enable without TSI		0		
8		CSI transmission	Off			On		0		

SW NO.	DATA NO.	ITEM	Switch setting and function						Initial setting	Remarks						
			1			0										
SW6	1	JBIG (Joint Bi-level Image Group)	On			Off			1							
	2	JBIG option	On			Off			0							
	3	MMR	On			Off			1							
	4	MR	On			Off			1							
		Modem speed		V.33		V.17		V. 29	V. 27ter							
	5		No. 5	0	0	1	1	1	1	0	0	0	0	1		
	6		No. 6	1	1	0	0	0	0	0	0	0	0	0	0	
	7		No. 7	0	1	0	1	0	1	0	1	1	0	0	0	
8		No. 8	0	0	0	0	1	1	1	1	0	0	0	0		
SW7	1	Reception speed fixed				NO	V. 17- 14400BPS	V. 29- 9600BPS	V. 27ter- 4800BPS			0	When 14400BPS MODEM used, setting to 14400BPS is ignored.			
	2		No. 1	0	1	0	1	0	0							
			No. 2	0	1	1	0	0	0							
	3	DIS receive acknowledge during G3 transmission	Twice			Once in NSF reception, twice in DIS reception			0	Effective to international comm.						
	4	Non-modulated carrier in V.29 transmission mode	On			Off			0							
	5	CNG send in manual transmission	On			Off			1							
	6	Protocol monitor	On			Off			0							
	7	Line monitor	On			Off			0							
8	Max. length for TX/RX/Copy	TX: unlimited, RX: unlimited			TX/Copy: 1.0m, RX: 1.5m			0								
SW8	1	Compromised equalizer				0Km	1.8Km	3.6Km	7.2Km			0	Valid when transmitting			
	2		No. 1	0	0	1	1	0	0							
			No. 2	0	1	0	1	0	1							
	3	H2 mode	No			Yes			0							
	4	Signal transmission level	Binary input			16	8	4	2	1	0					
	5		No. =			4	5	6	7	8 (Data No.)	1					
	6		EX			0	1	1	0	1	1					
	7		eg. Signal transmission level is set to -10dBm								0					
8												1				

SW NO.	DATA NO.	ITEM	Switch setting and function					Initial setting	Remarks	
			1		0					
SW9	1	CED tone signal interval		75ms	500ms	750ms	1000ms	0		
	2		No. 1	0	0	1	1			
	3		No. 2	0	1	0	1			
	4	Equalization freeze	On			Off			0	
	5	Equalization freeze conditions	All			7200bps			0	
	6	CED detection time	500ms			1000ms			0	
	7	Alarm buzzer		3sec	1sec	No BEEP	No BEEP	0		
	8		No. 5	0	0	1	1			
9	No. 6	0	1	0	1	0	0			
10	Action when RTN received	Not Error			Error			0		
SW10	1	Memory retransmission times	Binary input 8 4 2 1					1	OPTION	
	2		No. = 1 2 3 4 (Data No.)					0		
	3		EX 1 0 1 0					1		
	4		eg. Retransmission time set to 10 times.					0		
	5	Memory retransmission interval	Binary input 8 4 2 1					0	OPTION	
	6		No. = 5 6 7 8 (Data No.)					0		
	7		EX 0 0 1 0					1		
	8							0		
SW11	1	Reserved					1			
	2	Reserved					1			
	3	Reserved					1			
	4	Reserved					0			
	5	Reserved					1			
	6	Reserved					1			
	7	Reserved					1			
	8	Reserved					0			
SW12	1	Reserved					1			
	2	Reserved					1			
	3	Reserved					0			
	4	EOL detection timer		13sec	25sec	5sec	5sec	0		
	5		No. 4	0	0	1	1			
	6	Processing of DIS reception after DIS transmission		Retransmitting command	Breaking circuit	Apply to T.30	T.30+α	0		
	7		No. 6	0	0	1	1			
	8	No. 7	0	1	0	1	0			
9	The change to DB from DP by ✕	Yes			No			0		
SW13	1	DTMF output level (High)	Binary input 16 8 4 2 1					0		
	2		No. = 4 5 6 7 8 (Data No.) n = 0.5dBm					1		
	3		EX 0 1 1 0 0					1		
	4		eg. Signal transmission level is set to -10dBm					0		
	5							0		
	6	Reserved					0			
	7	Reserved					0			
	8	Reserved					0			
SW14	1	DTMF output level (Low)	Binary input 16 8 4 2 1					1		
	2		No. = 4 5 6 7 8 (Data No.) n = 0.5dBm					0		
	3		EX 1 0 0 0 0					0		
	4		eg. Signal transmission level is set to -10dBm					0		
	5							0		
	6	Reserved					0			
	7	Reserved					0			
	8	Reserved					0			

SW NO.	DATA NO.	ITEM	Switch setting and function								Initial setting	Remarks	
			1				0						
SW15	1	Reserved									0		
	2	Reserved									0		
	3	Reserved									0		
	4	Reserved									0		
	5	Reserved									0		
	6	Reserved									0		
	7	Reserved									0		
	8	Reserved									0		
SW16	1	Reserved									0		
	2	Reserved									0		
	3	Reserved									0		
	4	Reserved									0		
	5	CI Signal OFF detect enable time	(ms)	200	300	350	400	500	700	1200			
	6		No. 5	0	0	0	0	0	0	0	0		
	7		No. 6	0	0	0	0	1	1	1	1	1	
	8		No. 7	0	0	1	1	0	0	1	1	0	
8	No. 8	0	1	0	1	0	0	1	0	1			
SW17	1	Reserved									0		
	2	Reserved									0		
	3	Reserved									0		
	4	Reserved									0		
	5	Distinctive ringing		OFF	STD	RING1	RING2	RING3	RING4	RING5			
	6		No. 5	0	0	1	0	1	0	1	0		
	7		No. 6	0	0	0	1	1	0	0	0		
	8		No. 7	0	0	0	0	0	1	1	0		
8	No. 8	0	1	0	0	0	0	0	0	0			
SW18	1	Reserved									0		
	2	Reserved									0		
	3	Reserved									0		
	4	Reserved									0		
	5	Reserved									0		
	6	Reserved									0		
	7	Reserved									0		
	8	Reserved									0		
SW19	1	Reserved									0		
	2	Reserved									0		
	3	Reserved									0		
	4	Reserved									1		
	5	Reserved									1		
	6	Reserved									0		
	7	Reserved									0		
	8	Reserved									0		
SW20	1	Reserved									0		
	2	Reserved									0		
	3	Reserved									1		
	4	Reserved									1		
	5	Reserved									0		
	6	Reserved									0		
	7	Reserved									0		
	8	Reserved									0		

SW NO.	DATA NO.	ITEM	Switch setting and function					Initial setting	Remarks	
			1		0					
SW21	1	Reserved						1		
	2	Reserved						0		
	3	Reserved						0		
	4	Reserved						0		
	5	Reserved						1		
	6	Reserved						0		
	7	Reserved						0		
	8	Reserved						0		
SW22	1	Reserved						0		
	2	Reserved						0		
	3	Reserved						0		
	4	Reserved						0		
	5	Reserved						0		
	6	Reserved						0		
	7	Reserved						0		
	8	Reserved						0		
SW23	1	Reserved						0		
	2	Reserved						0		
	3	Reserved						0		
	4	Busy tone detection frequency		520-640Hz	300-600Hz	380-500Hz	reserve	reserve		
			No. 4	0	0	0	0	1	0	
			No. 5	0	0	1	1	0	0	
		No. 6	0	1	0	1	0	0	0	
7	Reserved							0		
8	Reserved							0		
SW24	1	Reserved						0		
	2	Reserved						0		
	3	Reserved						0		
	4	Reserved						0		
	5	Reserved						0		
	6	Reserved						0		
	7	Reserved						0		
	8	Reserved						0		
SW25	1	Reserved						0		
	2	Reserved						0		
	3	Reserved						0		
	4	Reserved						0		
	5	Reserved						0		
	6	Reserved						0		
	7	Reserved						0		
	8	Reserved						0		
SW26	1	Reserved						0		
	2	Reserved						0		
	3	Reserved						0		
	4	Reserved						0		
	5	Reserved						0		
	6	Reserved						0		
	7	Reserved						0		
	8	Reserved						0		

SW NO.	DATA NO.	ITEM	Switch setting and function					Initial setting	Remarks	
			1		0					
SW27	1	F.A.S.T (RMS) mode	On		Off			0		
	2	Reserved						0		
	3	Verification STAMP	Yes		No			0		
	4	Summer time (Day light saving)	No		Yes			1		
	5	Key buzzer volume		Off	HIGH	MIDDLE	LOW	1		
			No. 5	0	0	1	1			
			No. 6	0	1	0	1			
	7	Reserved						0		
8	Reserved						0			
SW28	1	Speaker volume		HIGH	HIGH	MIDDLE	LOW	1		
			No. 1	0	0	1	1			
			No. 2	0	1	0	1			
	3	Reserved						1		
	4	Reserved						0		
	5	Ringer volume		Off	HIGH	MIDDLE	LOW	1		
			No. 5	0	0	1	1			
			No. 6	0	1	0	1			
7	Reserved						0			
8	Reserved						0			
SW29	1	Reserved						0		
	2	PC I/F mode	On		Off			1	OPTION	
	3	Reserved						0		
	4	Reserved						0		
	5	Reserved						0		
	6	Reserved						0		
	7	Reserved						0		
	8	Reserved						0		
SW30	1	Header registration	On		Off			0		
	2	Reserved						0		
	3	Reserved						0		
	4	Reserved						0		
	5	Reserved						0		
	6	Reserved						0		
	7	Reserved						0		
	8	Quick on-line function	Yes		No			1		
SW31	1	Cassette selection		Manual	Auto-1	Auto-2	Auto-1	0	OPTION	
			No. 1	0	0	1	1			
	2		No. 2	0	1	0	1	1		
	3	The first priority cassette		None	Tray	1st. Cass.	2nd. Cass.	Tray	0	OPTION It is effective only when No.31-1/2 are set up of manual
			No. 3	0	0	0	0	Other		
			No. 4	0	0	1	1	Combination		
	5		No. 5	0	1	0	1	0		
	6	The second priority cassette		None	Tray	1st. Cass.	2nd. Cass.	Tray	0	OPTION It is effective only when No.31-1/2 are set up of manual
			No. 6	0	0	0	0	Other		
			No. 7	0	0	1	1	Combination		
			No. 8	0	1	0	1			

SW NO.	DATA NO.	ITEM	Switch setting and function						Initial setting	Remarks
			1			0				
SW32	1	The third priority cassette	None	Tray	1st. Cass.	2nd. Cass.	Tray	0	OPTION It is effective only when No.31-1/2 are set up of manual	
	2		No. 1	0	0	0	0			Other
	3		No. 2	0	0	1	1			Combination
	4	Reserved						1		
	5	Reserved						0		
	6	Reserved						0		
	7	Reserved						0		
	8	Print hold function	On		Off			0		
SW33	1	Heater mode		Always on	Always off		0	OPTION		
	2		No. 1	0	0					
	3	Density adjustment of print bias	Binary input 4 2 1					1	set to 1~6. set to 0, is equal to 4 (100).	
	4		No. = 3 4 5 (Data No.) 1: faint ~ 6: deep							
	5		EX 1 0 0 eg. Bias is set to level 4.							
	6	Reserved					0			
	7	Reserved					0			
	8	Reserved					0			
SW34	1	The default resolution for copying	Super fine		Fine		0	OPTION		
	2	Reserved					0			
	3	Reserved					0			
	4	Reserved					0			
	5	Reserved					0			
	6	Reserved					0			
	7	Reserved					0			
	8	Reserved					0			
SW35	1	Reserved					0			
	2	Reserved					1			
	3	Reserved					1			
	4	Reserved					1			
	5	Reserved					0			
	6	Reserved					1			
	7	Reserved					1			
	8	Reserved					0			
SW36	1	Reserved					0			
	2	Reserved					0			
	3	Reserved					1			
	4	Reserved					0			
	5	Reserved					0			
	6	Reserved					0			
	7	Reserved					0			
	8	Reserved					1			
SW37	1	Delay time after PC printing (n second)	Binary input 128 64 32 16 8 4 2 1						0	
	2		No. = 1 2 3 4 5 6 7 8 (Data No.)						0	
	3		EX 0 0 0 0 0 1 1 0 (= 6 secs)						0	
	4							0		
	5							0		
	6							1		
	7							1		
	8							0		

SW NO.	DATA NO.	ITEM	Switch setting and function		Initial setting	Remarks	
			1	0			
SW38	1	Reserved			0		
	2	Reserved			0		
	3	Reserved			0		
	4	Reserved			0		
	5	Reserved			0		
	6	Reserved			0		
	7	Reserved			0		
	8	Reserved			0		
SW39	1	Reserved			0		
	2	Reserved			0		
	3	Reserved			0		
	4	Reserved			0		
	5	Reserved			0		
	6	Reserved			0		
	7	Reserved			0		
	8	Reserved			0		
SW40	1	Reserved			0		
	2	Reserved			0		
	3	Reserved			0		
	4	Reserved			0		
	5	Reserved			0		
	6	Reserved			0		
	7	Reserved			0		
	8	Reserved			0		
SW41	1	Reserved			0		
	2	Reserved			0		
	3	Reserved			0		
	4	Reserved			0		
	5	Reserved			0		
	6	Reserved			0		
	7	Reserved			0		
	8	Reserved			0		
SW42	1	Reserved			0		
	2	Reserved			0		
	3	Reserved			0		
	4	Reserved			0		
	5	Reserved			0		
	6	Reserved			0		
	7	Reserved			0		
	8	Reserved			0		
SW43	1	Reserved			0		
	2	Reserved			0		
	3	Reserved			0		
	4	Reserved			0		
	5	Reserved			0		
	6	Data reduction (Prohibition of setting except Auto and 100%)		AUTO	100%	0	
	7		No. 6	0	1	0	
	8		No. 7	0	0	0	
		No. 8	0	0	0		
SW44	1	Automatic printing of activity report	Yes (When memory full)	No (First data is cleared when memory full)	0	OPTION	
	2	Print out of total time and total number of pages on activity report	Off	On	0		
	3	Reserved			0		
	4	Department function	On	Off	0		
	5	Department ID digit	Binary input	8 4 2 1	0	OPTION	
	6		No. =	5 6 7 8 (Data No.)	1	set to 3 ~ 9	
	7		EX	0 1 0 0	0		
	8		eg. Department is set to level 4.		0		

SW NO.	DATA NO.	ITEM	Switch setting and function					Initial setting	Remarks	
			1		0					
SW45	1	Picture quality priority mode	Fine		standard			0	OPTION	
	2	Cut off mode (When copy mode)	Continue		Cut -off			0	OPTION	
	3	Scanning ratio in memory input	1:1		Reduce			0	Memory Scanning	
	4	Overseas communication mode selection function	Yes		No			0		
	5	Reserved						0		
	6	Reduce ratio when copy mode (Prohibition of setting except Auto and 100%)			AUTO		100%	1		
	7		No. 6	0	0	1	0			
	8		No. 8	0	0	0	0			
SW46	1	Reserved						0		
	2	Reserved						0		
	3	Density adjustment (when Fine/STD mode)			Normal	Faint	Deep	0		
	4		No. 3	0	0	1	1			
	5	Density adjustment (when Half-tone mode)			Normal	Faint	Deep	0		
	6		No. 5	0	0	1	1			
	7	MTF correction in Half-tone mode	On		Off			1		
	8	MTF intensity in Half-tone mode	Strong		Weak			0		
SW47	1	Cassette define LTR/A4:Tray	A4		LTR			0		
	2	Cassette define LTR/A4:Upper	A4		LTR			0		
	3	Cassette define LTR/A4:Lower	A4		LTR			0		
	4	Reserved						0		
	5	Reserved						0		
	6	Reserved						0		
	7	Reserved						0		
	8	Reserved						0		
SW48	1	Reserved						1		
	2	Reserved						0		
	3	Reserved						0		
	4	Reserved						0		
	5	Reserved						0		
	6	Reserved						0		
	7	Reserved						0		
	8	Reserved						1		
SW49	1	Secure billing code	Yes		No			0		
	2	Pause with Z key	Yes		No			0		
	3	Reserved						0		
	4	Z key pause time (250ms unit)	Binary input		16	8	4	2	1	0
	5		No. =		4	5	6	7	8	(Data No.)
	6		EX		0	0	0	0	0	0
	7		eg. Pause time 250ms							0
	8	time = (n+1) x 250ms							0	
SW50	1	Separate feature	On		Off			0		
	2	Reserved						0		
	3	Reserved						0		
	4	Reserved						0		
	5	Addition of header (sender information)	On		Off			1		
	6	DTMF sending by the panel test	On		Off			0		
	7	Power save system	Real time		Timer			1		
	8	Reserved						0		

SW NO.	DATA NO.	ITEM	Switch setting and function		Initial setting	Remarks
			1	0		
SW51	1	Reserved			0	
	2	Reserved			0	
	3	Reserved			0	
	4	Reserved			0	
	5	Reserved			0	
	6	Reserved			0	
	7	Reserved			0	
	8	Reserved			0	
SW52	1	Reserved			0	
	2	Reserved			0	
	3	Reserved			0	
	4	Reserved			0	
	5	Reserved			0	
	6	Reserved			0	
	7	Reserved			0	
	8	Reserved			0	
SW53	1	Reserved			0	
	2	Reserved			0	
	3	Reserved			0	
	4	Reserved			0	
	5	Reserved			0	
	6	Reserved			0	
	7	Reserved			0	
	8	Reserved			0	
SW54	1	Reserved			0	
	2	Reserved			0	
	3	Reserved			0	
	4	Reserved			0	
	5	Reserved			0	
	6	Reserved			0	
	7	Reserved			0	
	8	Reserved			0	
SW55	1	Reserved			0	
	2	Reserved			0	
	3	Reserved			0	
	4	Reserved			0	
	5	Reserved			0	
	6	Reserved			0	
	7	Reserved			0	
	8	Reserved			0	
SW56	1	Reserved			0	
	2	Reserved			0	
	3	Reserved			0	
	4	Reserved			0	
	5	Reserved			0	
	6	Reserved			0	
	7	Reserved			0	
	8	Reserved			0	
SW57	1	Reserved			0	
	2	Reserved			0	
	3	Reserved			0	
	4	Reserved			0	
	5	Reserved			0	
	6	Reserved			0	
	7	Reserved			0	
	8	Reserved			0	

SW NO.	DATA NO.	ITEM	Switch setting and function		Initial setting	Remarks
			1	0		
SW58	1	Reserved			0	
	2	Reserved			0	
	3	Reserved			0	
	4	Reserved			0	
	5	Reserved			0	
	6	Reserved			0	
	7	Reserved			0	
	8	Reserved			0	
SW59	1	Reserved			0	
	2	Reserved			0	
	3	Reserved			0	
	4	Reserved			0	
	5	Reserved			0	
	6	Reserved			0	
	7	Reserved			0	
	8	Reserved			0	
SW60	1	Reserved			0	
	2	Reserved			0	
	3	Reserved			0	
	4	Reserved			0	
	5	Reserved			0	
	6	Reserved			0	
	7	Reserved			0	
	8	Reserved			0	
SW61	1	Reserved			0	
	2	Reserved			0	
	3	Reserved			1	
	4	Reserved			0	
	5	Reserved			0	
	6	Reserved			1	
	7	Reserved			0	
	8	Reserved			1	
SW62	1	Reserved			0	
	2	Reserved			0	
	3	Reserved			0	
	4	Reserved			0	
	5	Reserved			0	
	6	Reserved			0	
	7	Reserved			0	
	8	Reserved			0	
SW63	1	Reserved			0	
	2	Reserved			1	
	3	Waiting time after dialing	90 sec	Depends on each country's specifications	0	
	4	Reserved			0	
	5	Reserved			0	
	6	Reserved			0	
	7	Reserved			0	
	8	Reserved			0	

SW NO.	DATA NO.	ITEM	Switch setting and function		Initial setting	Remarks
			1	0		
SW64	1	Reserved			0	
	2	Reserved			0	
	3	Reserved			0	
	4	Reserved			0	
	5	Reserved			0	
	6	Reserved			0	
	7	Reserved			0	
	8	Reserved			0	
SW65	1	Reserved			0	
	2	Reserved			0	
	3	Reserved			0	
	4	Reserved			0	
	5	Reserved			0	
	6	Reserved			0	
	7	Reserved			0	
	8	Reserved			0	
SW66	1	Reserved			0	
	2	Reserved			0	
	3	Reserved			0	
	4	Reserved			0	
	5	Reserved			1	
	6	Reserved			1	
	7	Reserved			0	
	8	Reserved			1	
SW67	1	Reserved			0	
	2	Reserved			0	
	3	Reserved			0	
	4	Reserved			0	
	5	Reserved			0	
	6	Reserved			0	
	7	Reserved			0	
	8	Reserved			0	
SW68	1	Reserved			0	
	2	Reserved			0	
	3	Reserved			0	
	4	Reserved			0	
	5	Reserved			0	
	6	Reserved			0	
	7	Reserved			0	
	8	Reserved			0	
SW69	1	Reserved			0	
	2	Reserved			0	
	3	Reserved			0	
	4	Reserved			0	
	5	Reserved			0	
	6	Reserved			0	
	7	Reserved			0	
	8	Reserved			0	
SW70	1	Reserved			0	
	2	Reserved			0	
	3	Reserved			0	
	4	Reserved			0	
	5	Reserved			0	
	6	Reserved			0	
	7	Reserved			0	
	8	Reserved			0	

SW NO.	DATA NO.	ITEM	Switch setting and function		Initial setting	Remarks
			1	0		
SW71	1	Reserved			0	
	2	Reserved			0	
	3	Reserved			0	
	4	Reserved			0	
	5	Reserved			0	
	6	Reserved			0	
	7	Reserved			0	
	8	Reserved			0	
SW72	1	Reserved			0	
	2	Reserved			0	
	3	Reserved			0	
	4	Reserved			0	
	5	Reserved			0	
	6	Reserved			0	
	7	Reserved			0	
	8	Reserved			0	
SW73	1	Reserved			0	
	2	Reserved			0	
	3	Reserved			0	
	4	Reserved			0	
	5	Reserved			0	
	6	Reserved			0	
	7	Reserved			0	
	8	Reserved			0	
SW74	1	Reserved			0	
	2	Reserved			0	
	3	Reserved			0	
	4	Reserved			0	
	5	Reserved			0	
	6	Reserved			0	
	7	Reserved			0	
	8	Reserved			0	
SW75	1	Reserved			0	
	2	Reserved			0	
	3	Reserved			0	
	4	Reserved			0	
	5	Reserved			0	
	6	Reserved			0	
	7	Reserved			0	
	8	Reserved			0	
SW76	1	Reserved			0	
	2	Reserved			0	
	3	Reserved			0	
	4	Reserved			0	
	5	Reserved			0	
	6	Reserved			0	
	7	Reserved			0	
	8	Reserved			0	
SW77	1	Reserved			0	
	2	Reserved			0	
	3	Reserved			0	
	4	Reserved			0	
	5	Reserved			0	
	6	Reserved			0	
	7	Reserved			0	
	8	Reserved			0	

SW NO.	DATA NO.	ITEM	Switch setting and function		Initial setting	Remarks
			1	0		
SW78	1	Reserved			0	
	2	Reserved			0	
	3	Reserved			0	
	4	Reserved			0	
	5	Reserved			0	
	6	Reserved			0	
	7	Reserved			0	
	8	Reserved			0	
SW79	1	Reserved			0	
	2	Reserved			0	
	3	Reserved			0	
	4	Reserved			0	
	5	Reserved			0	
	6	Reserved			0	
	7	Reserved			0	
	8	Reserved			0	
SW80	1	Reserved			0	
	2	Reserved			0	
	3	Reserved			0	
	4	Reserved			0	
	5	Reserved			0	
	6	Reserved			0	
	7	Reserved			0	
	8	Reserved			0	
SW81	1	Reserved			0	
	2	Reserved			0	
	3	Reserved			0	
	4	Reserved			0	
	5	Reserved			0	
	6	Reserved			0	
	7	Reserved			0	
	8	Reserved			0	
SW82	1	Reserved			0	
	2	Reserved			0	
	3	Reserved			0	
	4	Reserved			0	
	5	Reserved			0	
	6	Reserved			0	
	7	Reserved			0	
	8	Reserved			0	
SW83	1	Reserved			0	
	2	Reserved			0	
	3	Reserved			0	
	4	Reserved			0	
	5	Reserved			0	
	6	Reserved			0	
	7	Reserved			0	
	8	Reserved			0	
SW84	1	Reserved			0	
	2	Reserved			0	
	3	Reserved			0	
	4	Reserved			0	
	5	Reserved			0	
	6	Reserved			0	
	7	Reserved			0	
	8	Reserved			0	

SW NO.	DATA NO.	ITEM	Switch setting and function		Initial setting	Remarks
			1	0		
SW85	1	Reserved			0	
	2	Reserved			0	
	3	Reserved			0	
	4	Reserved			0	
	5	Reserved			0	
	6	Reserved			0	
	7	Reserved			0	
	8	Reserved			0	
SW86	1	Reserved			0	
	2	Reserved			0	
	3	Reserved			0	
	4	Reserved			0	
	5	Reserved			0	
	6	Reserved			0	
	7	Reserved			0	
	8	Reserved			0	
SW87	1	Reserved			0	
	2	Reserved			0	
	3	Reserved			0	
	4	Reserved			0	
	5	Reserved			0	
	6	Reserved			0	
	7	Reserved			0	
	8	Reserved			0	
SW88	1	Reserved			0	
	2	Reserved			0	
	3	Reserved			0	
	4	Reserved			0	
	5	Reserved			0	
	6	Reserved			0	
	7	Reserved			0	
	8	Reserved			0	
SW89	1	Reserved			0	
	2	Reserved			0	
	3	Reserved			0	
	4	Reserved			0	
	5	Reserved			0	
	6	Reserved			0	
	7	Reserved			0	
	8	Reserved			0	
SW90	1	Reserved			0	
	2	Reserved			0	
	3	Reserved			0	
	4	Reserved			0	
	5	Reserved			0	
	6	Reserved			0	
	7	Reserved			0	
	8	Reserved			0	

SW NO.	DATA NO.	ITEM	Switch setting and function		Initial setting	Remarks
			1	0		
SW91	1	Reserved			0	
	2	Reserved			0	
	3	Reserved			0	
	4	Reserved			0	
	5	Reserved			0	
	6	Reserved			0	
	7	Reserved			0	
	8	Reserved			0	
SW92	1	Reserved			0	
	2	Reserved			0	
	3	Reserved			0	
	4	Reserved			0	
	5	Reserved			0	
	6	Reserved			0	
	7	Reserved			0	
	8	Reserved			0	
SW93	1	Reserved			0	
	2	Reserved			0	
	3	Reserved			0	
	4	Reserved			0	
	5	Reserved			0	
	6	Reserved			0	
	7	Reserved			0	
	8	Reserved			0	
SW94	1	Reserved			0	
	2	Reserved			0	
	3	Reserved			0	
	4	Reserved			0	
	5	Reserved			0	
	6	Reserved			0	
	7	Reserved			0	
	8	Reserved			0	
SW95	1	Reserved			0	
	2	Reserved			0	
	3	Reserved			0	
	4	Reserved			0	
	5	Reserved			0	
	6	Reserved			0	
	7	Reserved			0	
	8	Reserved			0	
SW96	1	Reserved			0	
	2	Reserved			0	
	3	Reserved			0	
	4	Reserved			0	
	5	Reserved			0	
	6	Reserved			0	
	7	Reserved			0	
	8	Reserved			0	

SW NO.	DATA NO.	ITEM	Switch setting and function		Initial setting	Remarks
			1	0		
SW97	1	Reserved			0	
	2	Reserved			0	
	3	Reserved			0	
	4	Reserved			0	
	5	Reserved			0	
	6	Reserved			0	
	7	Reserved			0	
	8	Reserved			0	
SW98	1	Reserved			0	
	2	Reserved			0	
	3	Reserved			0	
	4	Reserved			0	
	5	Reserved			0	
	6	Reserved			0	
	7	Reserved			0	
	8	Reserved			0	
SW99	1	Reserved			0	
	2	Reserved			0	
	3	Reserved			0	
	4	Reserved			0	
	5	Reserved			0	
	6	Reserved			0	
	7	Reserved			1	
	8	Reserved			1	

• Soft switch function description

SW1 No. 1 ~ No. 4 Recall interval

Choice is made for a recall interval for speed and rapid dial numbers. Use a binary number to program this. If set to 0 accidentally, 1 will be assumed.

SW1 No. 5 ~ No. 8 Recall times

Choice is made as to how many recall times should be made. Use a binary number to program this.

SW2 No. 1 Dial mode

Switch the type according to the telephone circuit connected to the facsimile.

- 0: PULSE DIAL
- 1: TONE DIAL

SW2 No. 2 Receive mode

Auto/manual receiving mode is set.

SW2 No. 3 ECM mode

Used to determine ECM mode function. Refer to the following table.

SW2 No. 4 Reserved

Set to "0".

SW2 No. 5 Polling security

This switch is employed to enable or disable the polling operation using the ID code verification function, in order to prevent unauthorized polling operation.

SW2 No. 6 Auto cover sheet

When "1" (=YES) is selected, the cover sheet is automatically sent after transmission of the original to notify the receiver of the number of original sheets transmitted.

SW2 No. 7 JUNK-FAX function in manual reception

It is set whether JUNK-FAX is functioned in the manual receiving mode or not.

SW2 No. 8 JUNK-FAX function

This function is used to receive data from a specific remote machine (station registered in entry mode). It is the function that refused a reception in the case that TSI of remote machine matched with fax number of the station registered.

- 0: No
- 1: Yes

SW3 No. 1 ~ No. 4 Number of rings for auto-receive (0: No ring receive)

When the machine is set in the auto receive mode, the number of rings before answering can be selected. It may be set from one to nine rings using a binary number. If the soft switch was set to 1, a direct connection is made to the facsimile. If it was set to 0 accidentally, receive ring is set to 1. If it was above 9, receive rings are set to 9.

SW3 No. 5 ~ No. 8 Switch to auto-receive from manual receive (0: No switch)

This setting allows machine to switch from manual to Auto Receive mode. Setting this number to 0 forces machine to stay in Manual receive mode. Entering the binary number 0 forces the machine to remain in the manual answer mode. If a number between 1 and 9 is entered, the machine will go into the answer mode after the given number of rings. However, it can be used as an ordinary telephone if the handset is taken off the hook before this programmed number is finished. If entry of a number above 9 by accident, it will be set to 9. In this case, it must be corrected to the proper number.

SW4 No. 1 ~ No. 3 Communication results printout

It is possible to obtain communication results after each transaction. Normally, the switch is set (No. 1: 0, No. 2: 0, No. 3: 1) so that the communication result is produced only a communication error is encountered. If No. 1 was set to 1, No. 2 was set to 1 and No. 3 was set to 0, the communication result will be produced every time a communication is done, even if the communication was successful.

If No. 1 was set to 0, No. 2 to 1 and No. 3 to 0, the communication result will be produced every transmission.

Setting No. 1 to 1 No. 2 to 0 and No. 3 to 0 will disable this function. No transaction report will be printed.

If No. 1 was set to 0, No. 2 to 0 and No. 3 to 0, the communication result is produced only after a timer and memory transmission or when a communication error is encountered.

SW4 No. 4 Image addition function to the communication result table (for memory transmission only)

Used to set addition of sending image to the communication result table.

SW4 No. 5 Reserved

Set to "0".

SW4 No. 6 TEL billing code function

When set to "1", the TEL billing code function is enabled.

SW4 No. 7 Billing code position

When set to "1", the billing code is delivered before dialing the remote number. When set to "0", the billing code is delivered after dialing.

SW4 No. 8 Multi-TTI feature

When this switch is set to "1", Multi TTI function is enabled.

SW5 No. 1 Time display format

When this switch is set to "0", time is displayed in 12-hour system. When set to "1", 24-hour system.

SW5 No. 2 Date display format

Used to select date display/print formats.

- 0: DAY-Month-Year
- 1: Month-DAY-Year

SW5 No. 3 Header print

When it is set at 0, sender's name, sending page number and so on are automatically printed in the recording paper on the receiving side during transmission. Thus, the sender can be known on the receiving side.

- 0: Applied.
- 1: Not applied.

SW5 No. 4 Footer print

When set to "1", the date of reception, the sender machine No., and the page No. are automatically recorded at the end of reception.

SW5 No. 5 Relay data output

- 0: Output ON
- 1: Output OFF

SW5 No. 6 Substitute reception

Selection of substitute reception in the case of recording paper exhausted or paper jam. If set to "NO", auto receive is disabled even when the receive memory is ready to receive.

Substitute reception is not performed even during receive operation.

SW5 No. 7 Substitute reception conditions

Selection of substitute reception according to existence of TEL number from transmitting side. Initial setting allows substitute reception without CSI. If set to "no", the receiver cannot receive any documents

SW5 No. 8 CSI transmission

CSI signal contains the sender's phone number registered in the machine. If this switch is set to "1", no sender's name will be printed at the receiving side.

SW6 No. 1 JBIG (Joint Bi-level Image Group)

An image compression encoding method recommended by ITU-T. It realizes 2-second transmission when the power is turned on.

SW6 No. 2 JBIG option

An optional function for JBIG.

SW6 No. 3 MMR

MMR (Modified MR) selects presence of the compression function.

SW6 No. 4 MR

MR (Modified READ) selects presence of the compression function.

SW6 No. 5 ~ No. 8 Modem speed

Used to determine the initial modem speed. The default is 14400BPS(V.17). It may be necessary to program it to a slower speed when frequent line fallback is encountered, in order to save the time required for the fallback procedure.

SW7 No. 1, No. 2 Reception speed fixed

The transferable speed of modem in the receiving mode is set.

SW7 No. 3 DIS receive acknowledge during G3 transmission

Used to make a choice of whether reception of NSF (DIS) is acknowledged after receiving two NSFs (DISs) or receiving one NSF (two DISs). It may be useful for overseas communication to avoid an echo suppression problem, if set to 1.

SW7 No. 4 Non-modulated carrier in V.29 transmission mode

Though transmission of a non-modulated carrier is not required for transmission by the V29 modem according to the CCITT Recommendation, it may be permitted to send a non-modulated carrier before the image signal to avoid an echo suppression problem.

It may be useful for overseas communication to avoid an echo suppression problem, if set to 1.

SW7 No. 5 CNG send in manual transmission

CNG signal sending ON/OFF in case of manual transmission is set.

SW7 No. 6 Protocol monitor

Normally set to "0". If set to "1", communication can be checked, in case of troubles, without using a G3 tester or other tools.

When communication FSK data transmission or reception is made, the data is taken into buffer. When communication is finished, the data analyzed and printed out. When data is received with the line monitor (SW7-No. 7) set to "1" the reception level is also printed out.

SW7 No. 7 Line monitor

Normally set to "0". If set to "1", the transmission speed and the reception level are displayed on the LCD. Used for line tests.

SW7 No. 8 Max. length for TX/RX/Copy

Used to set the maximum page length.

To avoid possible paper jam, the page length is normally limited to 432 mm for copy or transmit, and 1.5 meters for receive.

It is possible to set it to "No limit" to transmit/receive a long document, such as a computer print form, etc. (In this case, the receiver/transmitter must also be set to no limit.)

SW8 No. 1, No. 2 Compromised equalizer

The specific line equalizer is inserted.

No. 1 No. 2

0	0	The line equalizer built in the modem is turned off.
0	1	Line equalizer corresponding to 1.8 km
1	0	Line equalizer corresponding to 3.6 km
0	1	Line equalizer corresponding to 7.2 km

SW8 No. 3 H2 mode

Used to determine H2 mode (15sec transmission mode). When set to OFF, H2 mode is inhibited even though the transmitting machine has H2 mode.

SW8 No. 4 ~ No. 8 Signal transmission level

Used to control the signal transmission level in the range of -0dB to -31dB.

SW9 No. 1, No. 2 CED tone signal interval

For international communication, the 2100Hz CED tone may act as an echo suppresser switch, causing a communication problem. Though this soft switch is normally set to "0", it should be set to "1" so as to change the time between CED tone and DIS signal from 75ms to 500ms to eliminate the communication problem caused by echo.

SW9 No. 3 Equalization freeze

This switch is used to perform reception operation by fixing the equalizer control of modem for the line which is always in an unfavorable state and picture cannot be received. Usually, the control is executed according to the state of line where the equalizer setting is changed always.

SW9 No. 4 Equalization freeze conditions

Setting which specifies SW9 No.3 control only in condition of 7200bps modem speed.

SW9 No. 5 CED detection time

The detection time of the CED signal from the called side in the auto calling mode is set.

SW9 No. 6, No. 7 Alarm buzzer

The length of the buzzer for normal end of operation is set.

SW9 No. 8 Action when RTN received

The operation is set when the RTN signal is received in the G3 transmission mode.

SW10 No. 1 ~ No. 4 Memory retransmission times

The number of memory retransmissions is set.

SW10 No. 5 ~ No. 8 Memory retransmission interval

The interval between memory retransmissions is set.

SW11 No. 1 ~ No. 3 Reserved

Set to "1".

SW11 No. 4 Reserved

Set to "0".

SW11 No. 5 ~ No. 7 Reserved

Set to "1".

SW11 No. 8 Reserved

Set to "0".

SW12 No. 1, No. 2 Reserved

Set to "1".

SW12 No. 3 Reserved

Set to "0".

SW12 No. 4, No. 5 EOL detection timer

Used to make a choice of whether to use the 25-second or 13-second timer for detection of End of line This is effective to override communication failures with some facsimile models that have longer End of line detection.

SW12 No. 6, No. 7 Processing of DIS reception after DIS transmission

When receiving , operation in case of DIS reception after DIS transmission is selected.

Retransmitting command: To retransmit DIS in disregard of DIS reception.

Breaking circuit: To break circuit instantly. (Abnormal finish)

T. 30: To operate in accordance with T.30.

T. 30+α: To operate in accordance with T.30+α. (To operate differently according to cases.)

SW12 No. 8 The change to DB from DP by ✕

When setting to 1, the mode is changed by pressing the ✕ key from the pulse dial mode to the tone dial mode.

SW13 No. 1 ~ No. 5 DTMF output level (High)

To set the level to output high group DTMF signals. -15 to 0 dBm (0.5 dBm unit)

SW13 No. 6 ~ No. 8 Reserved

Set to "0".

SW14 No. 1 ~ No. 5 DTMF output level (Low)

To set the level to output low group DTMF signals. -15 to 0 dBm (0.5 dBm unit)

SW14 No. 6 ~ No. 8 Reserved

Set to "0".

SW15 No. 1 ~ No. 8 Reserved

Set to "0".

SW16 No. 1 ~ No. 4 Reserved

Set to "0".

SW16 No. 5 ~ No. 8 CI signal OFF detect enable time

Used to set the continuous detection time during OFF period of CI signal.

SW17 No. 1 ~ No. 4 Reserved

Set to "0".

SW17 No. 5 ~ No. 8 Distinctive ringing

When the ringing setting is turned off, all of the CI signal are received. When any of the standard, and ring patterns 1 through 3 is selected for the ringing setting, only the selected CI signal is received.

CI signal patterns

The CI signal patterns consists of the standard pattern, and ring patterns 1 through 7. The standard pattern is the conventional one.

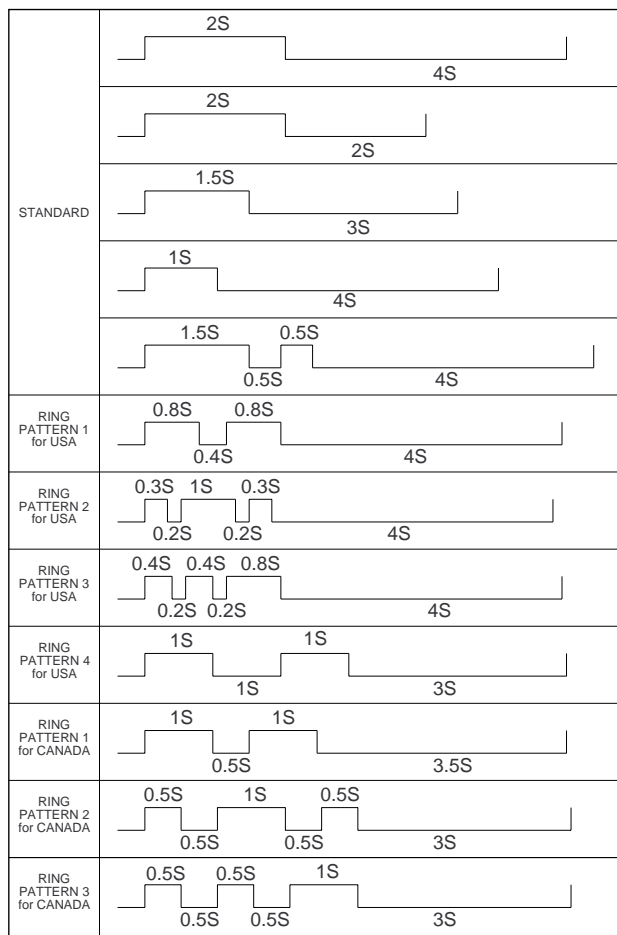

SW18 No. 1 ~ No. 8 Reserved

Set to "0".

SW19 No. 1 ~ No. 3 Reserved

Set to "0".

SW19 No. 4 , No. 5 Reserved

Set to "1".

SW19 No. 6 ~ No. 8 Reserved

Set to "0".

SW20 No. 1 , No. 2 Reserved

Set to "0".

SW20 No. 3 , No. 4 Reserved

Set to "1".

SW20 No. 5 ~ No. 8 Reserved

Set to "0".

SW21 No. 1 Reserved

Set to "1".

SW21 No. 2 ~ No. 4 Reserved

Set to "0".

SW21 No. 5 Reserved

Set to "1".

SW21 No. 6 ~ No. 8 Reserved

Set to "0".

SW22 No. 1 ~ No. 8 Reserved

Set to "0".

SW23 No. 1 ~ No. 3 Reserved

Set to "0".

SW23 No. 4 ~ No. 6 Busy tone detection frequency

To select frequency range of signals to be detected as Busy Tone.

SW23 No. 7, No. 8 Reserved

Set to "0".

SW24 No. 1 ~ No. 8 Reserved

Set to "0".

SW25 No. 1 ~ No. 8 Reserved

Set to "0".

SW26 No. 1 ~ No. 8 Reserved

Set to "0".

SW27 No. 1 F.A.S.T (RMS) mode

Used to determine a function of remote maintenance system (F.A.S.T).

SW27 No. 2 Reserved

Set to "0".

SW27 No. 3 Verification STAMP

End stamp:

It is set whether the red round mark is stamped at the bottom margin of the document of every page in the memory input mode and document sending mode or not.

SW27 No. 4 Summer time (Day light saving)

The day light saving function ON/OFF is set.

SW27 No. 5, No. 6 Key buzzer volume

Key buzzer volume:

The sound volume of key inputting buzzer and other buzzers is set.

SW27 No. 7, No. 8 Reserved

Set to "0".

SW28 No. 1, No. 2 Speaker volume

Speaker volume:

The sound volume of the speaker in the on-hook mode is set.

SW28 No. 3 Reserved

Set to "1".

SW28 No. 4 Reserved

Set to "0".

SW28 No. 5, No. 6 Ringer volume

Ringer volume:

The calling sound volume of CI signal receiving is set.

SW28 No. 7, No. 8 Reserved

Set to "0".

SW29 No. 1 Reserved

Set to "0".

SW29 No. 2 PC I/F mode

The interface with the personal computer is selected.

SW29 No. 3 ~ No. 8 Reserved

Set to "0".

SW30 No. 1 Header registration

When setting this switch to "1", registering senders is protected.

SW30 No. 2 ~ No. 7 Reserved

Set to "0".

SW30 No. 8 Quick on-line function

It is selected whether auto dial call is activated in the memory input mode when one document is completely read or when all pages are completely read.

SW31 No. 1, No. 2 Cassette selection

To set selective modes for detail paper cassettes of the printer.

00:	Manual	To select detail paper in the first priority cassette in accordance with setting by SW31 3-8 and SW32 1-3. If the detail paper in the first priority cassette runs short, the second priority cassette will be used.
01:	Automatic 1	To automatically select detail paper with optimum size among the first to third priority cassettes in accordance with setting by SW31 3-8 and SW32 1-3. The optimum paper is selected by every page. If all the cassettes have the same size paper, paper will be selected according to the cassette priority.
10:	Automatic 2	To automatically select detail paper with optimum size among the first to third priority cassettes in accordance with setting by SW31 3-8 and SW32 1-3. At the start of printing, the optimum paper is adopted only for the first page. Thereafter the same cassette selected for the first page will be used from the second page and after. If all the cassettes have the same size paper, paper will be selected according to the cassette priority.
11:	Except the above	Setting forbidden (01: the same setting as in the case of Automatic 1)

SW31 No. 3 ~ No. 5 The first priority cassette

To select the first priority cassette.

001:	1st paper feeder (MP-TRAY)
010:	2nd paper feeder
011:	3rd paper feeder
Except the above	Setting forbidden (Printing started from the possible paper feeder)

SW31 No. 6 ~ No. 8 The second priority cassette

To select the second priority cassette.

000:	Not used (To set in case of using only paper feeder that has been set in the first priority cassette)
001:	1st paper feeder (MP-TRAY)
010:	2nd paper feeder
011:	3rd paper feeder
Except the above	Setting forbidden (Not used)

SW32 No. 1 ~ No. 3 The third priority cassette

To select the third priority cassette.

000:	Not used (To set in case of using only paper feeder that has been set in the first /second priority cassette)
001:	1st paper feeder (MP-TRAY)
010:	2nd paper feeder
011:	3rd paper feeder
Except the above	Setting forbidden (Not used)

SW32 No. 4 ~ No. 7 Reserved

Set to "0".

SW32 No. 8 Print hold function

When set to "1", the print hold function is enabled.

SW33 No.1, No. 2 Heater mode

Used to set ON/OFF of the heater. Three settings are available: always ON, always OFF, and OFF timer. (Only when Off timer is selected, SW34-SW37 settings are valid.)

To set performance of the heater at the printer fixing part.

00:	Normally ON (Off in case of Save Mode, giving priority to Energy Save Mode)
01:	Normally OFF
Except the above	Setting forbidden (Normally OFF)

SW33 No. 3 ~ No. 5 Density adjustment of print bias

The density of printing is set.

It can be also set in the print diagnosis mode.

SW33 No. 6 ~ No. 8 Reserved

Set to "0".

SW34 No. 1 The default resolution for copying

In case of copying without pressing the RESOLUTION key, resolution will be super fine.

SW34 No. 2 ~ No. 8 Reserved

Set to "0".

SW35 No. 1 Reserved

Set to "0".

SW35 No. 2 ~ No. 4 Reserved

Set to "1".

SW35 No. 5 Reserved

Set to "0".

SW35 No.6, No. 7 Reserved

Set to "1".

SW35 No.8 Reserved

Set to "0".

SW36 No. 1, No. 2 Reserved

Set to "0".

SW36 No. 3 Reserved

Set to "1".

SW36 No. 4 ~ No. 7 Reserved

Set to "0".

SW36 No. 8 Reserved

Set to "1".

SW37 No. 1 ~ No. 8 Delay time after PC printing (n second)

To insert delay time after PC printing.

SW38 No. 1 ~ No. 8 Reserved

Set to "0".

SW39 No. 1 ~ No. 8 Reserved

Set to "0".

SW40 No. 1 ~ No. 8 Reserved

Set to "0".

SW41 No. 1 ~ No. 8 Reserved

Set to "0".

SW42 No. 1 ~ No. 8 Reserved

Set to "0".

SW43 No. 1 ~ No. 5 Reserved

Set to "0".

SW43 No. 6 ~ No. 8 Data reduction

Reduction ratio of receiving is set .

It can be changed even in the optional mode.

To set printing reduction rate of received images.

000:	Automatic
100:	100%
Except the above	100%

SW44 No. 1 Automatic printing of activity report

This soft switch is used to select; whether or not to produce the activity report when the memory is full (about 50 items). An activity report can be produced when the following key entry command is made.

"FUNC", "2", "#", "START"

After producing the activity report, all the data in the memory will be cleared.

When the switch function is set to "0" (NO), the data in memory will be deleted from the oldest as it reaches the maximum memory capacity (approx. 50 items).

SW44 No. 2 Printout of total time and total number of pages on activity report

Used to make a choice of whether the total communication time and pages are recorded in the activity report.

SW44 No. 3 Reserved

Set to "0".

SW44 No. 4 Department function

This model has the department audit feature, it has to be set to 1 to utilize this feature.

SW44 No. 5 ~ No. 8 Department ID digit

Used to set the department ID digit number .
When set to "D" , the number is "4" .

SW45 No. 1 Picture quality priority mode

Used to set the transmission mode which is automatically selected when the MODE key is not pressed. In the copy mode, however, the fine mode is automatically selected unless the MODE key is manually set to another mode.

SW45 No. 2 Cut-off mode (when copy mode)

When in copy, if the scanned data is out of the range of recording, the operator has one of the choices below using the switch.

0: Continue: Data is printed onto the next page with the last 20mm also printed at the beginning of the next page.

1: Cut off: Data scanned out of the limit is cut off (a page is printed.)

SW45 No. 3 Scanning ratio in memory input

In the case of memory transmission, etc., only letter size (A4) documents can be stored in the memory. To input B4 documents into the memory, therefore, the B4 documents must be reduced to letter size (A4) or the both ends of the B4 documents will be cut off to input the center letter-size (A4) portion. This switch provides the selection.

0: Reduced to A4 size and inputted.

1: Both ends are cut off and the center portion (A4 size) is inputted.

SW45 No. 4 Overseas communication mode selection function

When this switch is set to "1", the communication is Super G3 mode can be turned off by pressing the "SPACE" key before sending operation, for the transmission set after that (including polling).

SW45 No. 5 Reserved

Set to "0".

SW45 No. 6 ~ No. 8 Reduce ratio when copy mode

Reduction ratio of copying is set .
It can changed even in the optional mode.

SW46 No. 1, No. 2 Reserved

Set to "0".

SW46 No. 3, No. 4 Density adjustment (when Fine/STD mode)

This is used for density adjustment in fine/standard mode. Adjust the density according to that of frequently used original.

Set to "Dark" for darker reading (either in the auto or the dark mode) of light original. Set to "Light" for lighter reading (either in the auto or the dark mode) of dark original.

Set to "Dark only in dark mode" for darker reading only in the dark mode.

SW46 No. 5, No. 6 Density adjustment (when Half-tone mode)

This is used for density adjustment in the half tone. Setting procedures are the same as SW46 No. 3 and No. 4.

SW46 No. 7 MTF correction in Half-tone mode

In the half tone mode, image area is separated from character area and processed separately to eliminate unclear character transmission. This switch is used to change the criteria of judgement of separation. When "Strong" (= 1) is selected, more area is judged as character area, providing clearer characters.

On the contrary, however, edges of image area may be emphasized.

It is advisable to restrict the use of this function only when clear characters must be transmitted, and to use the function of "Weak" (= 0) for general cases.

SW46 No. 8 MTF intensity in Half-tone mode

This allows selection of MTF correction (dimness correction) in the half tone mode. When "NO" (= 1) is selected, the whole image becomes soft and mild, On the contrary, however, mildness of characters will be reduced. Normally set to "NO" (= 1).

SW47 No. 1 Cassette define LTR / A4:Tray

A4 cassette can be used .

Set "0" or "1" for all of three bits.

Do not change the setting during printing.

SW47 No. 2 Cassette define LTR / A4:Upper

A4 cassette can be used .

Set "0" or "1" for all of three bits.

Do not change the setting during printing.

SW47 No. 3 Cassette define LTR / A4:Lower

A4 cassette can be used .

Set "0" or "1" for all of three bits.

Do not change the setting during printing.

SW47 No. 4 ~ No. 8 Reserved

Set to "0".

SW48 No. 1 Reserved

Set to "1".

SW48 No. 2 ~ No. 7 Reserved

Set to "0".

SW48 No. 8 Reserved

Set to "1".

SW49 No. 1 Secure billing code

When the Tel. Billing Code function is ON, the operation of SECURE BILLING CODE is enabled .

SW49 No. 2 Pause with Z key

The Z key pause time is set.

SW49 No. 3 Reserved

Set to "0".

SW49 No. 4 ~ No. 8 Z key pause time (250ms unit)

The Z key pause time is set.

SW50 No. 1 Separate feature

The separate mode ON/OFF is set.

SW50 No. 2 ~ No. 4 Reserved

Set to "0".

SW50 No. 5 Addition of header (sender information)

ON/OFF of addition of header (sender information) to various list is set.

SW50 No. 6 DTMF sending by the panel test

When ten keys are pressed in the Panel Test Mode of the diagnosis, the corresponding DTMF signals are output.

SW50 No. 7 Power save system

To switch Power Save Mode system either to Real Time or to Timer.

SW50 No. 8 Reserved

Set to "0".

SW51 No. 1 ~ No. 8 Reserved

Set to "0".

SW52 No. 1 ~ No. 8 Reserved

Set to "0".

SW53 No. 1 ~ No. 8 Reserved

Set to "0".

SW54 No. 1 ~ No. 8 Reserved

Set to "0".

SW55 No. 1 ~ No. 8 Reserved

Set to "0".

SW56 No. 1 ~ No. 8 Reserved

Set to "0".

SW57 No. 1 ~ No. 8 Reserved

Set to "0".

SW58 No. 1 ~ No. 8 Reserved

Set to "0".

SW59 No. 1 ~ No. 8 Reserved

Set to "0".

SW60 No. 1 ~ No. 8 Reserved

Set to "0".

SW61 No. 1, No. 2 Reserved

Set to "0".

SW61 No. 3 Reserved

Set to "1".

SW61 No. 4, No. 5 Reserved

Set to "0".

SW61 No. 6 Reserved

Set to "1".

SW61 No. 7 Reserved

Set to "0".

SW61 No. 8 Reserved

Set to "1".

SW62 No. 1 ~ No. 8 Reserved

Set to "0".

SW63 No. 1 Reserved

Set to "0".

SW63 No. 2 Reserved

Set to "1".

SW63 No. 3 Waiting time after dialing

The set up of the call time of the auto dial.
90 sec. or depends on each country's specifications.

SW63 No. 4 ~ No. 8 Reserved

Set to "0".

SW64 No. 1 ~ No. 8 Reserved

Set to "0".

SW65 No. 1 ~ No. 8 Reserved

Set to "0".

SW66 No. 1 ~ No. 4 Reserved

Set to "0".

SW66 No. 5, No. 6 Reserved

Set to "1".

SW66 No. 7 Reserved

Set to "0".

SW66 No. 8 Reserved

Set to "1".

SW67 No. 1 ~ No. 8 Reserved

Set to "0".

SW68 No. 1 ~ No. 8 Reserved

Set to "0".

SW69 No. 1 ~ No. 8 Reserved

Set to "0".

SW70 No. 1 ~ No. 8 Reserved

Set to "0".

SW71 No. 1 ~ No. 8 Reserved

Set to "0".

SW72 No. 1 ~ No. 8 Reserved

Set to "0".

SW73 No. 1 ~ No. 8 Reserved

Set to "0".

SW74 No. 1 ~ No. 8 Reserved

Set to "0".

SW75 No. 1 ~ No. 8 Reserved

Set to "0".

SW76 No. 1 ~ No. 8 Reserved

Set to "0".

SW77 No. 1 ~ No. 8 Reserved

Set to "0".

SW78 No. 1 ~ No. 8 Reserved

Set to "0".

SW79 No. 1 ~ No. 8 Reserved

Set to "0".

SW80 No. 1 ~ No. 8 Reserved

Set to "0".

SW81 No. 1 ~ No. 8 Reserved

Set to "0".

SW82 No. 1 ~ No. 8 Reserved

Set to "0".

SW83 No. 1 ~ No. 8 Reserved

Set to "0".

SW84 No. 1 ~ No. 8 Reserved

Set to "0".

SW85 No. 1 ~ No. 8 Reserved

Set to "0".

SW86 No. 1 ~ No. 8 Reserved

Set to "0".

SW87 No. 1 ~ No. 8 Reserved

Set to "0".

SW88 No. 1 ~ No. 8 Reserved

Set to "0".

SW89 No. 1 ~ No. 8 Reserved

Set to "0".

SW90 No. 1 ~ No. 8 Reserved

Set to "0".

SW91 No. 1 ~ No. 8 Reserved

Set to "0".

SW92 No. 1 ~ No. 8 Reserved

Set to "0".

SW93 No. 1 ~ No. 8 Reserved

Set to "0".

SW94 No. 1 ~ No. 8 Reserved

Set to "0".

SW95 No. 1 ~ No. 8 Reserved

Set to "0".

SW96 No. 1 ~ No. 8 Reserved

Set to "0".

SW97 No. 1 ~ No. 8 Reserved

Set to "0".

SW98 No. 1 ~ No. 8 Reserved

Set to "0".

SW99 No. 1 ~ No. 6 Reserved

Set to "0".

SW99 No. 7, No. 8 Reserved

Set to "1".

[3] Troubleshooting

1. Fax troubleshooting

Refer to the following actions to troubleshoot any of the problems mentioned in 1-4.

- [1] A communication error occurs.
- [2] Image distortion produced.
- [3] Unable to do overseas communication.
- [4] Communication speed slow due to FALLBACK.
 - Increase the transmission level SOFT SWITCH 8-4, 5, 6, 7, 8
May be used in case [1] [2] [3].
 - Decrease the transmission level SOFT SWITCH 8-4, 5, 6, 7, 8
May be used in case [3].

- Apply line equalization SOFT SWITCH 8-1, 2
May be used in all cases.
- Slow down the transmission speed SOFT SWITCH 6-5, 6, 7, 8
May be used in case [2] [3].
- Replace the LIU PWB.
May be used in all cases.
- Replace the control PWB.
May be used in all cases.

* If transmission problems still exist on the machine, use the following format and check the related matters.

TO: _____ ATT: _____ Ref.No.: _____
 CC: _____ ATT: _____ Date: _____
 FM: _____ Dept: _____
 _____ Sign: _____

***** Facsimile communication problem *****		Ref.No.: _____																				
From: Mr. _____ Fax Tel No.: _____		Date: _____																				
Our customer	Name _____	Tel No. _____																				
	Address _____	Fax No. _____																				
	Contact person _____	Model name _____																				
Other party	Name _____	Tel No. _____																				
	Address _____	Fax No. _____																				
	Contact person _____	Model name _____																				
Problem mode	Line: Domestic / international _____ Mode: G3 _____ Phase: A. B. C. D. _____																					
	Reception / Transmission _____ Automatic reception / Manual reception _____ Automatic dialing / Manual dialing / Others _____																					
Frequency: _____ %	ROM version: _____																					
Confirmation item		Please mark problem with an X No problem is: 0																				
		<table border="1" style="display: inline-table; border-collapse: collapse;"> <tr> <td style="width: 20px;">A1</td><td style="width: 20px;">A2</td><td style="width: 20px;">B1</td><td style="width: 20px;">B2</td><td style="width: 20px;">C1</td><td style="width: 20px;">C2</td><td style="width: 20px;">D1</td><td style="width: 20px;">D2</td><td style="width: 20px;">E1</td><td style="width: 20px;">E2</td> </tr> <tr> <td style="text-align: center;"> </td><td style="text-align: center;"> </td><td style="text-align: center;"> </td><td style="text-align: center;"> </td><td style="text-align: center;"> </td><td style="text-align: center;"> </td><td style="text-align: center;"> </td><td style="text-align: center;"> </td><td style="text-align: center;"> </td><td style="text-align: center;"> </td> </tr> </table>	A1	A2	B1	B2	C1	C2	D1	D2	E1	E2										
		A1	A2	B1	B2	C1	C2	D1	D2	E1	E2											
Transmission level setting is () dB at our customer																						
Transmission level () dBm Reception level () dBm By level meter at B1 and B2																						
Comment																						
Countermeasure																						
**** Please attach the G3 data and activity report on problem. ****																						

[4] Error code table**1. Communication error code table****G3 Transmission**

Code	Final received signal	Error Condition (Receiver side)
0	Incomplete signal frame	Cannot recognize bit stream after flag
1	NSF, DIS	Cannot recognize DCS signal by echo etc. Cannot recognize NSS signal (FIF code etc)
2	CFR	Disconnects line during reception (carrier missing etc)
3	FTT	Disconnects line by fallback
4	MCF	Disconnects line during reception of multi page Cannot recognize NSS, DCS signal in the case of mode change
5	PIP or PIN	The line is hung up without replying to telephone request from the receiving party.
6	RTN or RTP	Cannot recognize NSS, DCS signal after transmit RTN or RTP signal.
7	No signal or DCN	No response on receiver side or DCN signal received* (transmitter side)
8	–	Owing to error in some page the error could not be corrected although the specified number of error retransmission was attempted.
11	–	Error occurred after or while reception by the remote (receiving) machine was revealed to be impossible.
12	–	Error occurred just after fallback.
13	–	Error occurred after a response to retransmission end command was received.

G3 Reception

Code	Final received signal	Error Condition (Receiver side)
0	Incomplete signal frame	Cannot recognize bit stream after flag
1	NSS, DCS	Cannot recognize CFR or FTT signal Disconnects line during transmission (line error)
2	NSC, DTC	Cannot recognize NSS signal (FIF code etc)
3	EOP	Cannot recognize MCF, PIP, PIN, RTN, RTP signal
4	EOM	Cannot recognize MCF, PIP, PIN, RTN, RTP signal in the case of mode change
5	MPS	The line is hung up without replying to communication request.
6	PR1-Q	Cannot recognize PIP, PIN signal in the case of TALK request
7	No signal or DCN	No response in transmitter (cannot recognize DIS signal) or DCN signal received* (receiver side)
8	–	Error occurred upon completion of reception of all pages.
9	–	Error occurred when mode was changed or Transmission/Reception switching was performed.
10	–	Error occurred during partial page or physical page reception.
11	–	Error occurred after or during inquiry from the remote (transmitting) machine as to whether reception is possible or not.
12	–	Error occurred during or just after fallback.
13	–	Error occurred after the retransmission end command was received.

2. Service call error message

1. HEATER ERROR
2. LASER ERROR
3. POLYGON ERROR
4. FAN ERROR
5. PCU COMM, ERROR